



# LAPIS

[www.ndlapidary.org.au](http://www.ndlapidary.org.au)

"SHARE YOUR KNOWLEDGE"

VOLUME FORTY NUMBER SEVEN APRIL 2006

## **CLUB NEWS**

The next General meeting will be on Tuesday 11 April 2006. The meeting will start at **8 pm** and will be followed by a social evening which will give everyone a chance to talk and get to know other members better.

## **EXHIBITION NOTES**

**Dates for our 2006 Exhibition  
26<sup>th</sup> to 29<sup>th</sup> October 2006.**

We are again seeking coloured faceting rough to have cut and made available for sale at the exhibition. Please leave any contributions with a committee member. Please check your suppliers at home and if you can spare some faceting rough it will be much appreciated.

The hall booking has been confirmed.

## **CUTTING ROOM**

### **VINYL BUFFS**

We are presently trying a different type of vinyl on both the hard and the soft vinyl polish buffs. It is a light duty flooring vinyl that we are buying from Bunnings. The previous type was a softer upholstery vinyl. The black and white squares pattern does however give some unusual visual effects as the buff rotates. It appears as if this may be better type for our application but we need your feedback and comments

Even though it is a stronger vinyl it can still be damaged or worn out quickly with misuse. The main problem occurs when polishing back bevels, the thin edge of the bevel can cut deeply into the

buff. It is good practice to always use the outer part of the buff for back bevels and leave the central portion to polish the back of the Cab.

If the vinyl is badly damaged then it should be replaced. Take care when removing the old disc from the soft buff as the backing rubber can be damaged. Spare discs are kept on the top shelf of the cupboard where we keep the loose grit. Spread a thin coat of disc cement on the disc, let it dry for a few minutes and then stick it on.

### **SAFETY GOGGLES**

The Club supplies safety goggles for Member's use when using the grinders and trim saws. There are also goggles for sale in the Club shop for those Members who prefer to have their own.

### **GOOD FAIRIES**

Did you know that our Club has a number of fairies, elves and gnomes who are very active around the Clubrooms? They are seldom seen, but the work they put in is very obvious, our rooms get cleaned, garbage bins get emptied, chairs are set up for meetings, clean tea towels are always there and lots and lots more. However they always need more helpers so here is some information for you so you can help out.

The pantry cupboard in the kitchen between the fridge and the stove is normally well stocked with paper towels, matches, garbage bags and coffee cups etc. Food stocks are kept in the right hand pantry cupboard, tea towels and tablecloths are to the right under the servery and cleaning items are under the sink or in the broom cupboard. If something is needed then just get it out. If something needs cleaning or washing then do it. If garbage bin is full then take the bag up to the Council bin at the top of the pathway.



## TRIVIA QUESTIONS

Used at the Games Night that was held on 11 February 2006.

### Answers

1. What is lapidary ?
  - c. The art of cutting stones
2. What is a Cabachon ?
  - a. A cut stone shape
3. What is meant by Bevel Set ?
  - c. A type of stone setting used in jewellery making
4. How many facets on an American cut standard brilliant cut stone ?
  - b. 58
5. What is Scrimshaw ?
  - b. A type of carving/etching
6. Where is the next GEMBOREE being held [State] ?
  - b. Tasmania
7. What year will it be held there again ?
  - b. 2010
8. Who won the Club Championship at the GEMBOREE last year ?
  - a. NDLC [NSW]
9. Who won it in 2004 ?
  - c. Nunawading
10. What is a back bevel ?
  - a. Part of the cut on a cabochon
11. What is our Club Motto ?
  - b. Share your knowledge
12. What is an opal doublet ?
  - b. A thin piece of opal with a black patch backing
13. What was the specified material at the Gawler GEMBOREE for the Open Std Cab section ?
  - b. "bl--dy" banded calcite
14. List two forms of grinding equipment in our club rooms
  - a. Carbide wheels
  - b. Diamond wheels
15. What is the most common polish medium used at our club ?
  - b. Cerium
16. What was the last edition of Lapis called ?
  - a. January
17. Was it correct ?
  - b. No
18. At the Bathurst GEMBOREE how many people won the Open Std Cab Trophy ?
  - c. Three

19. How many vehicles on the last Nundle trip had to be towed home ?
  - a. One
20. Who is going to win the 2006 Club Championship Trophy in Hobart [GEMBOREE] ?
  - c. Us

## Insurance for Tailgaters at GEMBOREES & GAMKHANAS

The Gem & Lapidary Council of N.S.W. have advised that they will no longer be able to acquire "block insurance" for tailgaters at GEMBOREES or GEMKHANAS. Tailgaters must take out their own policy and forward a copy of same of same to Gem & Lapidary Council before the event. Further the gem Council advises that the policy must include the actual name of the person who is insured. Additionally Clubs should remember the moment they sell trading space to any person, that person is not covered by the Club's Public Risk Policy.

Taken from the Feb 06 Edition of Gem & Lapidary News.

## ARE YOU IMMUNISED AGAINST TETANUS ?

An article in a recent Gem and Lapidary News edition is a timely reminder to all about Tetanus immunisation.

Given our hobby of "playing" with stones, which are inevitably covered in dirt and grime; the use of machinery, which can remove bits of skin, and the fact that our hobby involves us in outdoor activities, being immunised against tetanus is probably a very good thing.

This involves three injections: The second is six weeks after the first, and the third is six months later, with a booster injection about every ten years. Not a lot involved for safety and peace of mind for those that work in gardens or pick up rocks etc. - particularly when they are FREE from your local GP.

Tony Try  
FTO

## CHAINS

Chains are an essential part of jewellery, but one we sometimes don't think too much about,

especially if the chain is designed to stay in the background to make another component the center of attention.

There are some designs to help you identify what chain you are buying.

Some of the most popular types of chains:

**Box Chain Illustration**

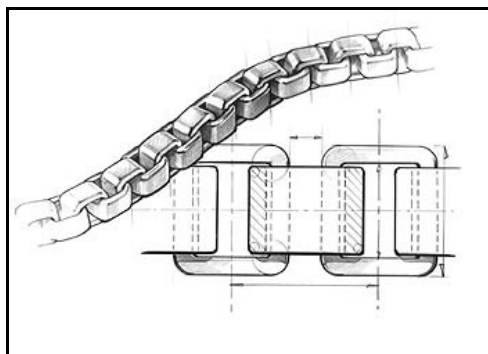

A box chain is made up of square links that are connected to create a smooth chain.

**Wheat Chain Illustration**

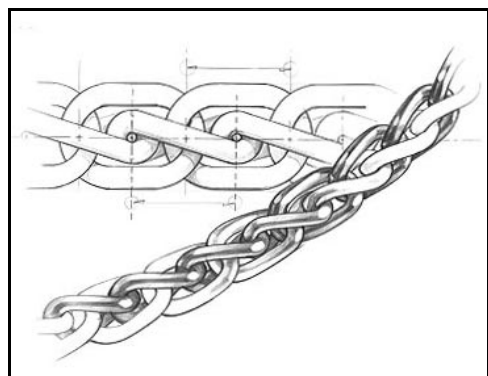

To make a wheat chain, oval and twisted oval links are connected and intertwined together. The result is an intricate chain with a great deal of visual texture

**Rolo Chain Illustration**

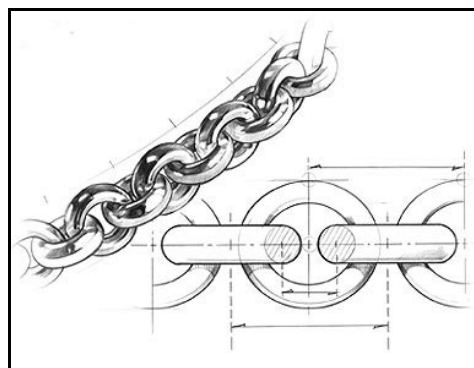

A rolo chain is made up of symmetrical links that are joined together.

**More Popular Chains**



Most chain jewelry is made from one kind of chain, but you'll see many pieces that are assembled with multiple chain types. Combining chains gives designers one more tool they can use to tap into their creativity.

Taken from website [Jewelry.about.com](http://Jewelry.about.com)



**Funnies**

**THE STONE SOUP STORY**

Once upon a time somewhere in Eastern Europe, there was a great famine. People jealously hoarded whatever food they could find, hiding it even from their friends and neighbors. One day a peddler drove his wagon into a village, sold a few of his wares, and began asking questions as if he planned to stay for the night.

“There’s not a bite to eat in the whole province,” he was told. “Better keep moving on.”

“Oh, I have everything I need,” he said “In fact. I was thinking of making some stone soup to share with all of you.”

He pulled an iron cauldron from his wagon, filled it with water, and built a fire under it. Then with great ceremony he drew an ordinary-looking stone from a velvet bag and dropped it into the water.

By now, hearing the rumor of food, most of the villagers had come to the square or watched from their windows. As the peddler sniffed the "broth" and licked his lips in anticipation, hunger began to overcome their skepticism.

"Ahh," the peddler said to himself rather loudly, "I do like a tasty stone soup. Of course, stone soup with CABBAGE – that's hard to beat."

Soon a villager approached hesitantly, holding a cabbage he'd retrieved from its hiding place, and added it to the pot. "Capital!" cried the peddler. "You know, I once had stone soup with cabbage and a salt beef as well, and it was fit for a king."

The village butcher managed to find some salt beef ...and so it went, through potatoes, onions, carrots, mushrooms and so on, until there was indeed a delicious meal for all. The villagers offered the peddler a great deal of money for the magic stone, but he refused to sell and traveled on the next day. And from that time on, long after the famine had ended, they reminisced about the finest soup they'd ever had.

### **THIS IS A CLEAN STORY.**

A man from Texas, driving a Volkswagen Beetle, pulls up next to a guy in a Rolls Royce at a stop sign.

Their windows are open and he yells at the guy in the Rolls, "Hey, you got a telephone in that Rolls?"

The guy in the Rolls says, "Yes, of course I do.."

"I got one too... see?" the Texan says.

"Uh, huh, yes, that's very nice."

"You got a fax machine?" asks the Texan.

"Why, actually, yes, I do."

"I do too! See? It's right here!" brags the Texan.

The light is just about to turn green and the guy in the Volkswagen says, "So, do you have a double bed in back there?"

The guy in the Rolls replies, "NO! Do you?"

Yep, got my double bed right in back here," the Texan replies.

The light turns and the man in the Volkswagen takes off.

Well, the guy in the Rolls is not about to be one-upped, so he immediately goes to a customizing shop and orders them to put a double bed in back of his car.

About two weeks later, the job is finally done. He picks up his car and drives all over town looking for the volkswagen beetle with the Texas plates. Finally, he finds it parked alongside the road, so he pulls his Rolls up next to it.

The windows on the Volkswagen are all fogged up and he feels somewhat awkward about it, but he gets out of his newly modified Rolls and taps on the foggy window of the Volkswagen.

=====  
(It's ok... The joke is CLEAN.)  
=====

The man in the Volkswagen finally opens the window a crack and peeks out.

The guy with the Rolls says, "Hey, remember me?" "Yeah, yeah, I remember you," replies the Texan, "What's up?"

"Check this out...I got a double bed installed in my Rolls."

"The Texan exclaims, "YOU GOT ME OUT OF THE SHOWER TO TELL ME THAT

*"To err is human. To err doing the same dumb thing twice is just dumb"*

### **Isn't ageing wonderful!**

I've sure gotten old. I've had two bypass surgeries, a hip replacement, new knees. Fought prostate cancer and diabetes. I'm half blind, can't hear anything quieter than a jet engine, take 40 different medications that make me dizzy, winded, and subject to blackouts. Have bouts with dementia. Have poor circulation; hardly feel my hands and feet anymore. Can't remember if I'm 85 or 92. Have lost all my friends. But, thank God, I still have my driver's license.

An elderly woman decided to prepare her will and told her preacher she had a final requests. She wanted to be buried at Bunnings. "Bunnings?" the preacher exclaimed. "Why Bunnings?" "Then I'll be sure my daughters visit me twice a week."





## DATES OF INTEREST

- April 11**                    **NORTHERN DISTRICTS LAPIDARY CLUB**  
**General Meeting Tuesday 8 pm, Clubrooms Beecroft. This will be a small meeting as many members are away at the GEMBOREE. There is no speaker for this meeting**
- April 22&23**                Blue Mtns Lapidary Club Gem Show, Progress Hall Bullaburra Sat 9-5 Sun 9-12
- April 29**                    Central Coast Lapidary Club Annual Rock Auction, Lot 7 Ourimbah Creek Road Ourimbah.  
Garage sale from 7am, auction starts at 12 noon.
- April 29**                    Nepean District Lapidary Club, Craft & Jewellery Sale, 12 North Street Penrith 9-4.
- May 9**                      **NORTHERN DISTRICTS LAPIDARY CLUB**  
General Meeting Tuesday 8 pm, Clubrooms Beecroft all members welcome
- May 20 or 21**              Enamelling Workshop – One day only –Bookings required. Please see list on club notice board.
- May 20- 21**                Lismore Club: 16<sup>th</sup> Gemfest “Pot of Gold” Showground, Alexander Pde, Nth Lismore
- May or June**              Precious Metal Clay Work day – Dates to be advised
- June 3 -4**                  Canberra Show – EPIC
- June 9-12**                 Gosford Show – Gosford Showground
- June 17**                    **Northern Districts Lapidary Club – 40<sup>th</sup> Birthday Party**  
**Cheltenham Recreation Club From 6pm, meal served at 7pm. All members and partners welcome!! Please see the booking form on the back of LAPIS**
- June 17 – 18**              Windsor Show    Windsor
- 26 – 29 Oct 2006**        Northern Districts Lapidary Club – Biennial Exhibition
- 2006 – GEMBOREE – Tasmania, Hobart April 14-17**  
**2007 – GEMBOREE – Queensland, Gatton – April 6-9**

For information on Interstate and Overseas Gem Shows see back pages of the Gem & Lapidary News available in clubrooms on shelf near library.



### Northern Districts Lapidary Club Shirts

Good quality polo shirts are available from the shop for field trips and future GEMBOREE'S.

They are royal blue with the Club's badge embroidered above the pocket on the left hand side of the shirt.  
Cost is \$35.00.                      Sizes range from small to XXXL.

If your size is not available in the shop please complete the form below.

Please indicate the size and number you require.                      **Name:**.....

**Size:**.....**Number:**.....

Return to Secretary NDLC – PO Box 59, Beecroft NSW 2119

**Lapis now available by  or  !!**

Members if you would prefer to receive your LAPIS by email rather than by snail mail please send you email address to John Andersen. John's email is [bonstyle@bigpond.net.au](mailto:bonstyle@bigpond.net.au).

Northern  Districts

**Lapidary Club**

*"Share your knowledge"*

**40<sup>th</sup> Anniversary Dinner !!!**

**Saturday 17<sup>th</sup> June 2006**



**Northern Districts Lapidary Club is celebrating its 40th Birthday !**

**Venue:**

**Cheltenham Recreation Club**

**Time:**

**From 6pm, meal served at 7pm.**

All members and partners very welcome!!

3 Course Meal with choice of two dishes for each course

\$30.00 per person.

Please complete the booking form below  
and

send your payment to the Secretary  
**before Friday 9 June 2006.**

Yes, I/we would like to attend the Northern Districts Lapidary Club Dinner on Saturday 17<sup>th</sup> June.

Names: .....  
.....

Payment enclosed for ..... people at \$30.00 per person, total payment \$.....

Please send your payment to

Secretary  
Northern Districts Lapidary Club  
PO Box 59, Beecroft NSW 2119

**before Friday 9 June 2006.**